

General Description

The Digital Blocks DB8279 Programmable Keyboard / Display Interface core is a full function equivalent to the Intel 8279 / Mitsubishi 8279 / NEC uPD8279 devices.

The DB8279 simultaneously and independently interface a keyboard and display to a microprocessor. The keyboard section provides a scanned interface to a 64-contact key matrix keyboard. The display section contains a 16x8 display RAM which refreshes a numeric or alphanumeric segment display.

Features

The DB8279 contains the following features:

- Simultaneous and independent scanning of a keyboard and refresh of a display, significantly offloading these functions from the microprocessor.
- Keyboard section:
 - 8-character Keyboard FIFO
 - 2-Key Lockout or N-key Rollover with Contact Debounce
 - Interrupt Output on Key Entry
 - Programmable Keyboard Scan & Debounce rates
- Display Section:
 - Dual 8- or 16-Numeric Display
 - Single 16-Character Display
 - Right or Left Entry 16-Byte Display RAM with address autoincrement
 - Programmable display refresh rate
- Available in VHDL, Verilog, or FPGA-Specific Netlist

Block Diagram

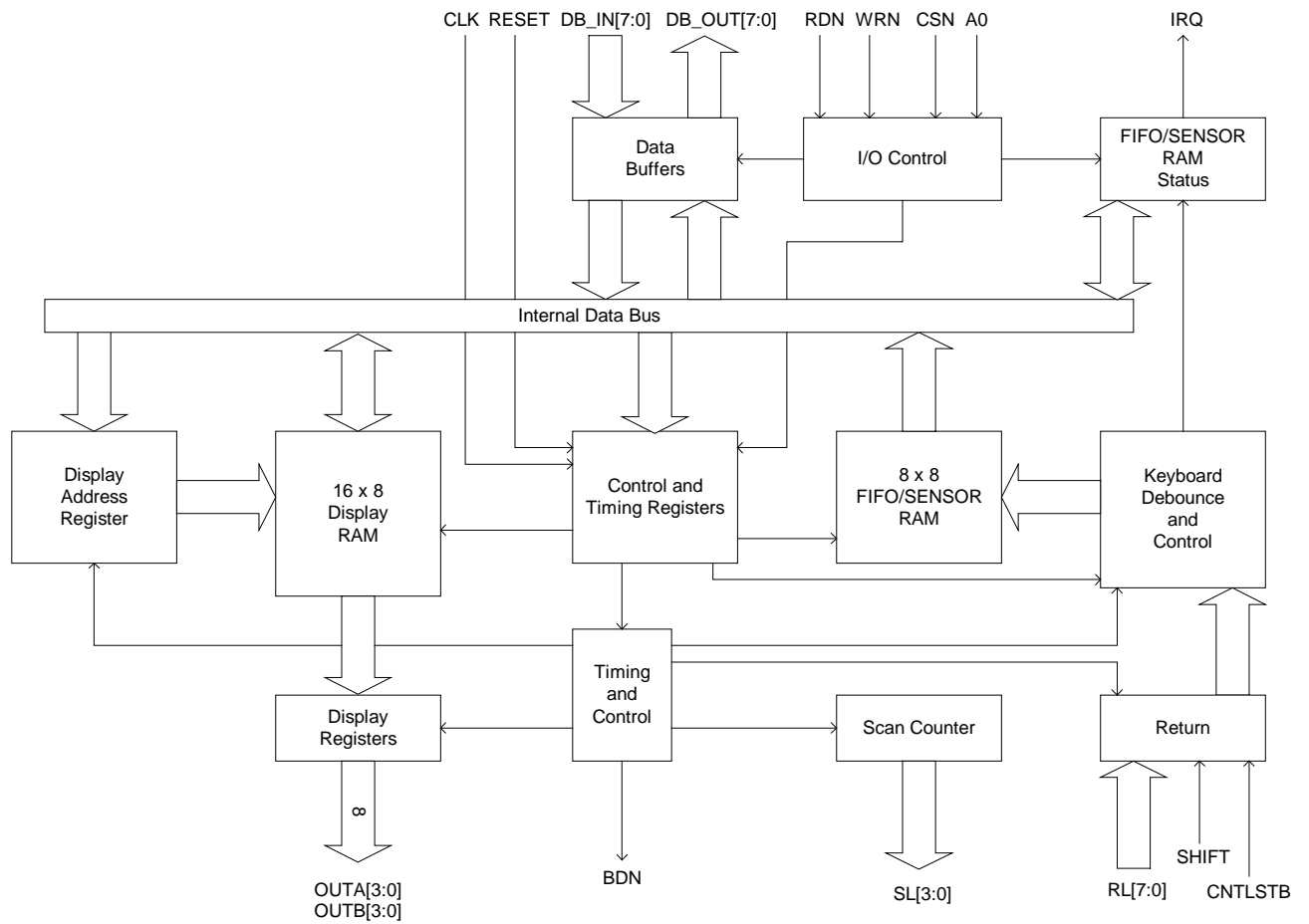

Figure 1: DB8279 Programmable Keyboard / Display Block Diagram

Pin Description

Name	Type	Polarity	Description
CLK	In	Rising	Clock
RESET	In	High	Reset
CSN	In	Low	Chip Select
A0	In	-	Buffer Address
RDN	In	Low	Input/Output Read
WRN	In	Low	Input/Output Write
RL[7:0]	In	-	Return Lines
SHIFT	In	-	Shift Input Status
CNTSTB	In	-	Control/Strobed Input Mode
DB_IN[7:0]	In	-	Data Bus (input side)
DB_OUT[7:0]	Out	-	Data Bus (output side)
PDBTRI	Out	Low	Tri-State signal for DB_OUT
IRQ	Out	-	Interrupt Request
SL[3:0]	Out	-	Scan Lines
OUTA[3:0]	Out	-	Outputs A for 16x4 display refresh registers
OUTB[3:0]	Out	-	Outputs B for 16x4 display refresh registers
BDN	Out	Low	Blank Display

Table 1: DB8279 Programmable Keyboard / Display Interface I/O Pin Description

Verification Methods

The DB8279 Programmable Keyboard / Display Interface cores function was verified by means of a proprietary hardware modeler. The same stimulus was applied to a hardware model that contained the original Intel 8279 chip, and the results compared with the core's simulation outputs. The DB8279 has been verified in silicon via customer designs.

Deliverables

The DB8279 Programmable Keyboard / Display Interface is available in VHDL or Verilog source or an FPGA-specific netlist. The IP Core comes with a comprehensive test suite, synthesis scripts, data sheet, and user manual. The test suite includes a testbench, test vectors and expected results.

Ordering Information

Please contact Digital Blocks for additional technical, pricing, and support information.

Digital Blocks, Inc.
PO Box 192
587 Rock Rd
Glen Rock, NJ 07452 USA
Phone: +1-201-251-1281
eFax: +1-702-552-1905
info@digitalblocks.com

Copyright © Digital Blocks, Inc. 1999-2017, ALL RIGHTS RESERVED